

M★RAK®

**GRP
Cable
Management
System**





CONTENTS

What is GRP.....	3
Why use GRP Products.....	4
Technical Specifications.....	5
Recommended Supports.....	6
Loading Capacity.....	7
M*RAK Cable Ladder Technical Guide.....	8
GRP G Series Ladder, Extra Heavy Duty.....	9
GRP G Series Ladder, Heavy Duty.....	10
GRP G Series Ladder, Medium Duty.....	11
GRP Cable Ladder (Horizontal Elbow).....	12
GRP Cable Ladder (Equal/Unequal Tee).....	13
GRP Cable Ladder (Crossover).....	14
GRP Cable Ladder (Riser).....	15
GRP Cable Ladder (Reducer).....	16
GRP Cable Ladder (Accessories).....	17
M*RAK Cable Tray Technical Guide.....	18
GRP Cable Tray (Straight).....	19
GRP Cable Tray (Horizontal Elbow).....	20
GRP Cable Tray (Crossover).....	21
GRP Cable Tray (Angle Riser).....	22
GRP Cable Tray (Reducer).....	23
GRP Cable Tray (Accessories).....	24
GRP Cable Tray (Accessories).....	25
Bolting Accessories.....	26

What is GRP?

Glass-Fibre Reinforced Polymers are composite products made of glass fibre and polymer resins, which when combined, offers a range of improved chemical and mechanical properties such as better corrosion resistance, longer durability, and better fire resistance, as compared with metallic products.

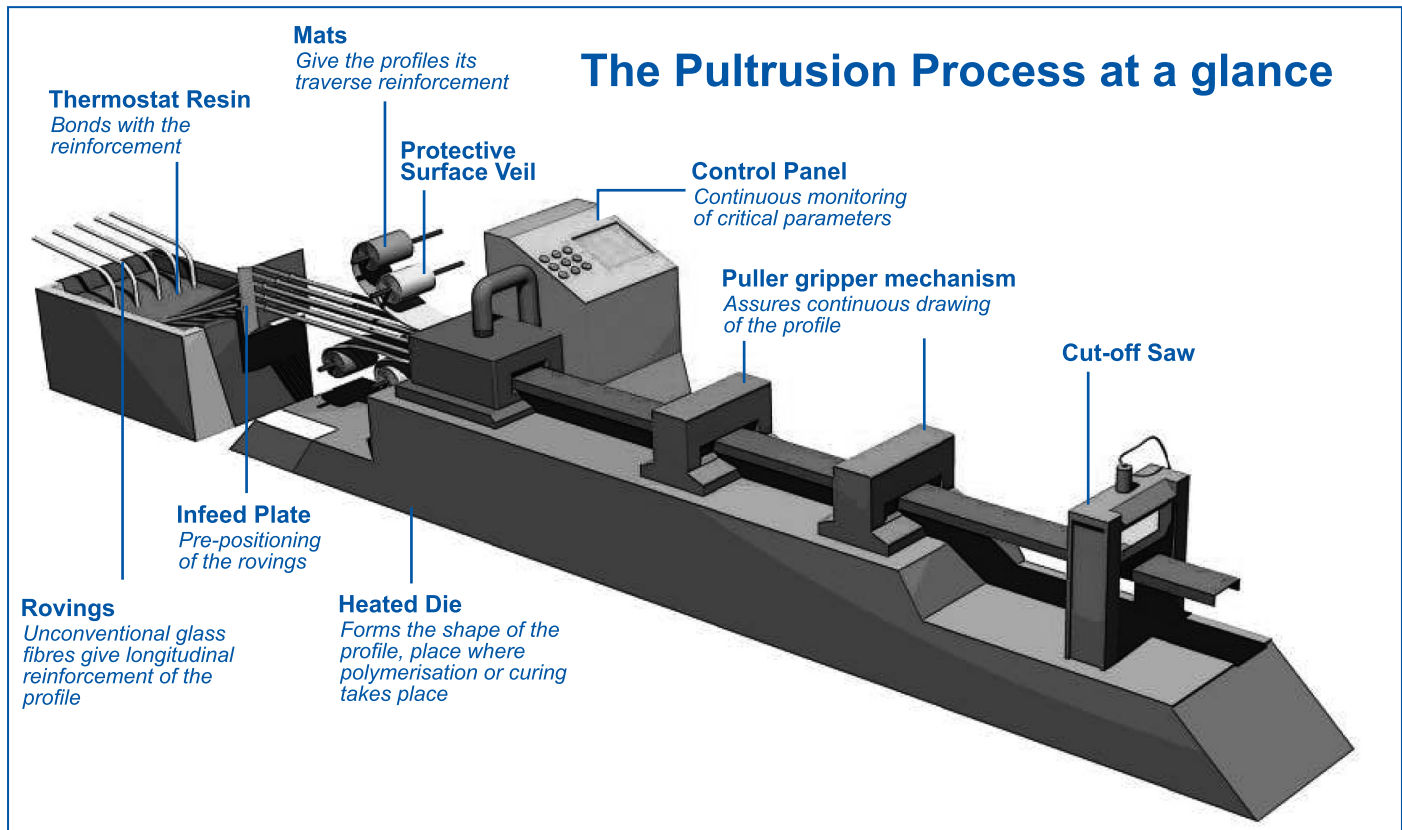

GRP Manufacturing Flow Chart

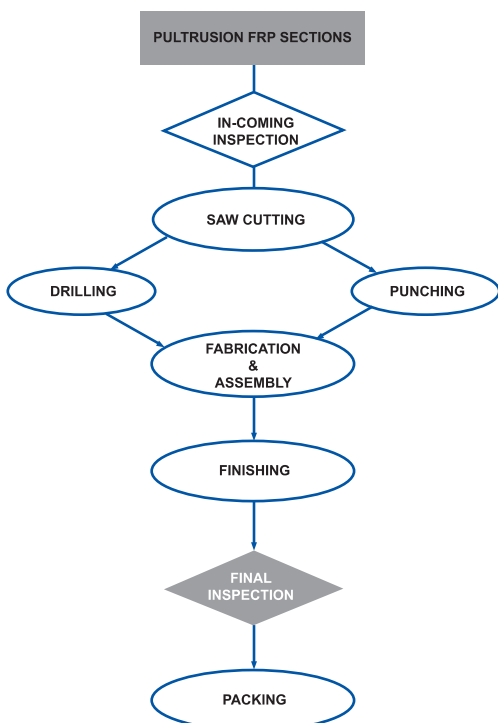

The pultrusion process starts with racks or creels holding rolls of fiber mat or doffs of fiber roving. This raw fiber is pulled off the racks and guided through a resin bath or resin impregnation system. Resin can also be injected directly into the die in some pultrusion systems. As the resin rich fiber exits the resin impregnation system, the un-cured composite material is guided through a series of tooling, which helps to arrange and organize the fiber into the correct shape. Continuous strand mat and surface veils are added in this step to increase structure and surface finish. The impregnated fibers are then passed through a heated steel die to obtain the desired cross section. Curing of the thermostat resin is initiated by heat in the die and catalyst in the resin. The profile that exits the die is now a cured pultruded Glass-Fibre Reinforced Polymer (GRP) composite. The GRP profile is pinched and pulled by a “gripper” system continuously. At the end of this pultrusion machine is a cut-off saw, where the GRP profile will be cut to length and ready for use. Our profiles are made up of more than 50% glass-fibre content to ensure mechanical integrity.

Why use GRP Products?

At Tri-Star, we are committed to fulfilling the requirements of our customers and to provide them with the added engineering value in all our offers. M*RAK GRP composites have many advantages over traditional materials such as steel or aluminium, which greatly minimises maintenance, significantly reducing the cost of ownership of the product over its project life span.

This improved technology has led to improved durability and strength in hostile and corrosive environments such as fuel storage tanks, chemical process plants, seawater desalination plants, wastewater treatment plants, semiconductor plants, power generator facilities and many more.



Rusting of metallic trays in a corrosive environment



GRP cable ladder

Benefits of using M*RAK GRP products

- **Corrosion Resistance**

GRP Products have excellent performance when used with most traditionally corrosive substances and are suitable for use in most harsh and saline conditions in offshore and marine environments. This property is often the primary reason for choosing GRP.

- **Minimal Maintenance**

GRP Products contain Ultra-Violet stabilizers and are further complimented with an external surface veil ensuring a longer life span than steel products.

- **Light Weight**

GRP Products are lighter than structural steel by 15% to 20% on average while still maintaining high strength.

- **Toughness**

Laminates are designed to withstand exposure to impact, abrasion, heat and cold.

- **High Strength**

GRP composites have a higher tensile strength than structural steel on a weight to weight ratio. Our products are made up of more than 50% glass-fiber content to ensure mechanical integrity.

- **Low Thermal Conductivity**

GRP Products have low thermal conductivity and are non-conductive which means that the effects of fire are localised.

- **Easy Installation**

GRP Products are easily cut and drilled using simple hand metal-working tools. Modifications can also be made simple and there is no need for re-galvanising of cut edges.

- **Low Expansion/Contraction**

There is less movement in response to temperature changes.

- **Fire Retardant**

Self-extinguishing, to BS 476 Part 1.

- **New Patented Stainless Steel Ring Insert**

Stronger and more stable rungs.

- **UV-Resistant**

Maintains physical integrity when used in outdoor installations.

M*RAK GRP Cable Trays and Ladders system complies with international standards in the areas as follows;

TESTS AND STANDARDS

Load Tested to
NEMA FG-1:1993

Flame Propagation
BS 476 Part 6

Halogen Free to
IEC 60754-1

Fire Rating
BS 476 Part 7
ASTM E84 Class 1&2

Available in
Polyester, Acrylic, Phenolic
and Modar resins

Oxygen Index
ASTM D2863-10

Material Content
More than 50% glass fibre

Water Absorption to
ASTM D570

Barcol Hardness tested to
ASTM D2583

Self Extinguishing to
UL94-VO

Ultraviolet (UV) Resistance
All M*RAK GRP Products have
additional surface veils added for
UV resistance, to ASTM G154

Working (Allowable) Load

The Working load capacity represents the destruction load capacity, with a minimum of 1.5 safety factor.

Load Classifications (NEMA FG-1-1993)

Class	Working Load	Support Span
A	50 Lb./Linear Ft. (74.4 kg/m)	20 Ft.
B	75Lb./Linear Ft. (111.6 kg/m)	20 Ft.
C	100Lb./Linear Ft. (148.8 kg/m)	20 Ft.



We are
BV-certified to
NEMA FG-1



SBN INDUSTRIES SDN BHD

M*RAK Cable Support System

LOAD TEST REPORT FOR FIBERGLASS CABLE LADDER SYSTEM C Profile Straight Cable Ladder - FRP (900mmW x 150mmH x 6M, 6.0THK)





NEMA FG 1-1993

LOAD / SPAN CLASS DESIGNATION

20B (1008 kg/m)

Loaded to Destruction (Until Collapse)

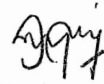
DATE : 7th Sept. 2010

PREPARED BY	WITNESSED BY
  Mahdzir (ASST. MGR)	  Mr. Abd. Latif (BUREAU VERITAS)

SPLICE PLATE LOCATION

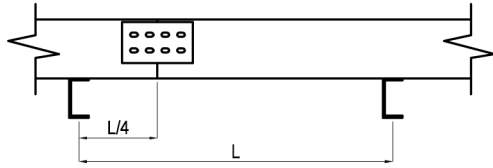

As per NEMA FG1, splice plate is recommended to be located at 1/4 of the span from the support, where the bending moment is zero.

SUPPORT LOCATION

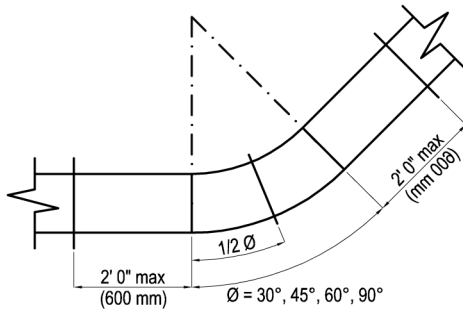

HORIZONTAL ELBOWS

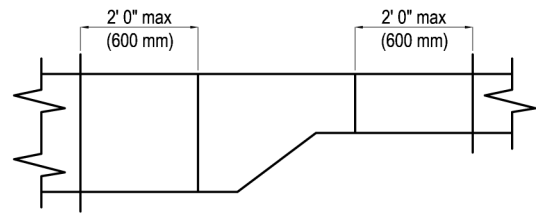

OFFSET REDUCER

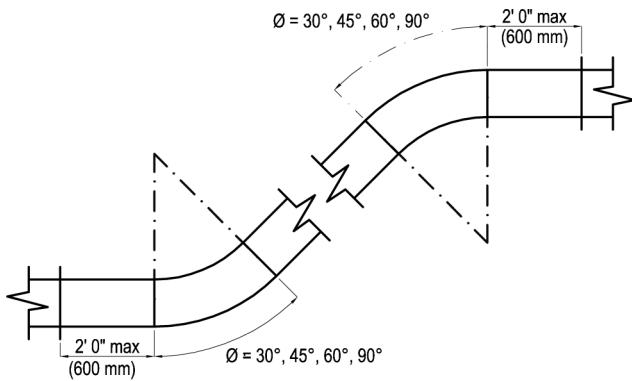

VERTICAL ELBOWS

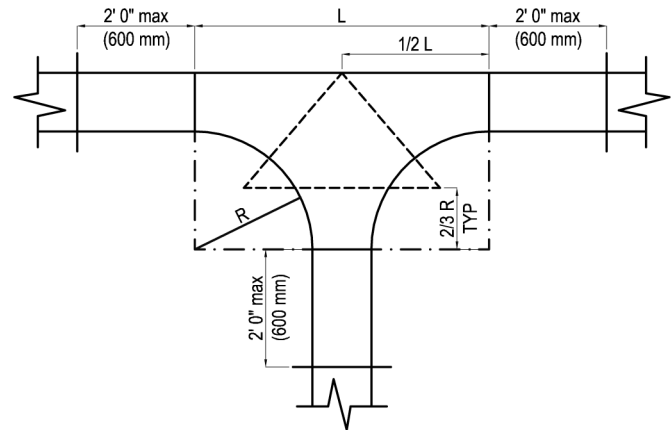

HORIZONTAL TEE

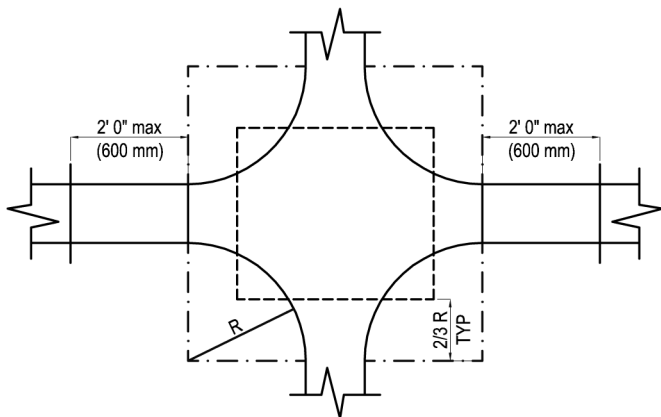

HORIZONTAL CROSS

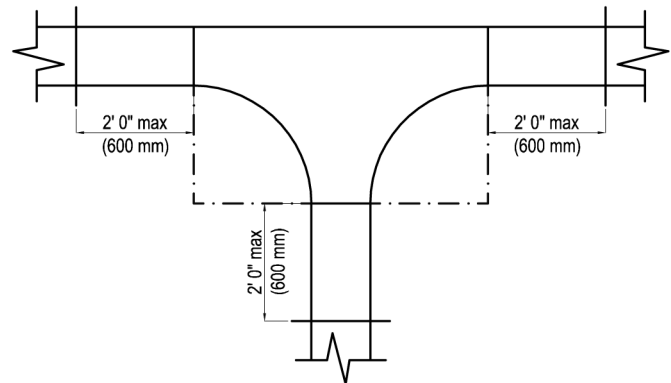

VERTICAL TEE

Load Designation of G-series Ladder

Side Rail Height (mm)	Duty Type	NEMA FG 1-1993																
		8A	8B	8C	12A	12B	12C	16A	16B	16C	20A	20B	20C					
100	Medium																	
150	Heavy																	
150	Extra Heavy																	

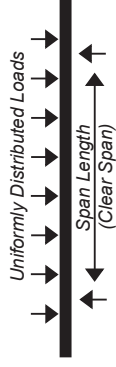

Choosing Your Cable Support Systems

Cable Ladder
High working load capacity, more suitable for heavier cables.

Perforated Cable Tray
Versatile, lighter and easy to install. Lighter duty and suitable for lower working load requirements.

Choose your cable tray support system according to your cable load and designed support span.

NEMA Standard classification in Table shows minimum working load with 1.5 Safety Factor.

Working Load Lbs/ft (kg/m)	Support Span Feet (m)	Class Designation Per 3.1
50 (74.4)	8 (2.44)	8A
75 (111.6)	8 (2.44)	8B
100 (148.8)	8 (2.44)	8C
50 (74.4)	12 (3.66)	12A
75 (111.6)	12 (3.66)	12B
100 (148.8)	12 (3.66)	12C
50 (74.4)	16 (4.87)	16A
75 (111.5)	16 (4.87)	16B
100 (148.8)	16 (4.87)	16C
50 (74.4)	20 (6.09)	20A
75 (111.6)	20 (6.09)	20B
100 (148.8)	20 (6.09)	20C

Table 1

WORKING LOAD CAPACITY (FOR FRP CABLE LADDER) NEMA 16C - 1095.15 kg/Support span

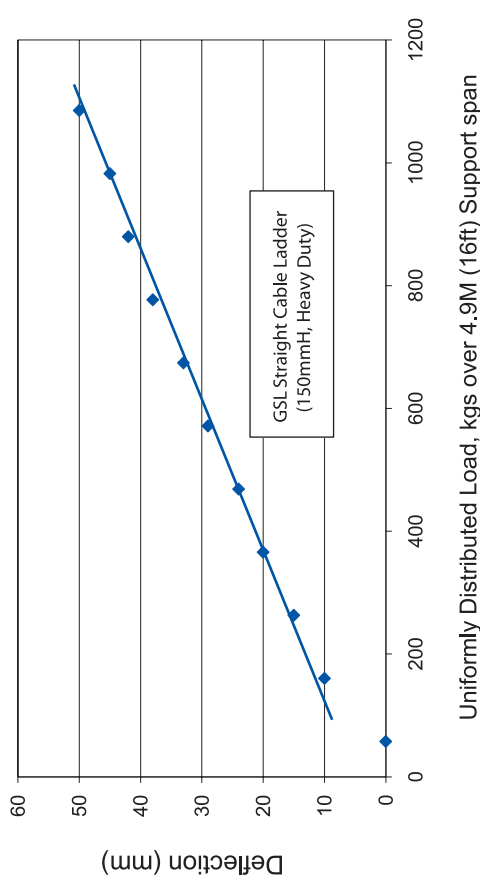

Note : The allowable working loads on other support spans are also available upon request.

WORKING LOAD CAPACITY (FOR FRP CABLE LADDER) NEMA 20C - 1341 kg/Support span

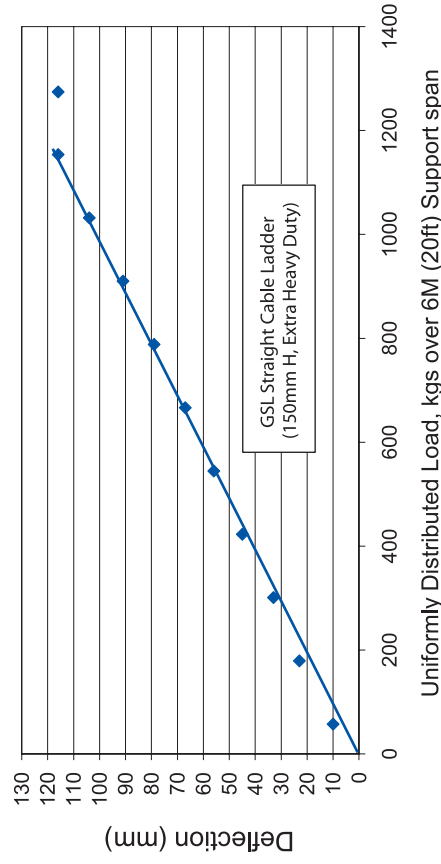

Note : The allowable working loads on other support spans are also available upon request.

WORKING LOAD CAPACITY (FOR FRP CABLE LADDER) NEMA 12C - 826.95 kg/Support span

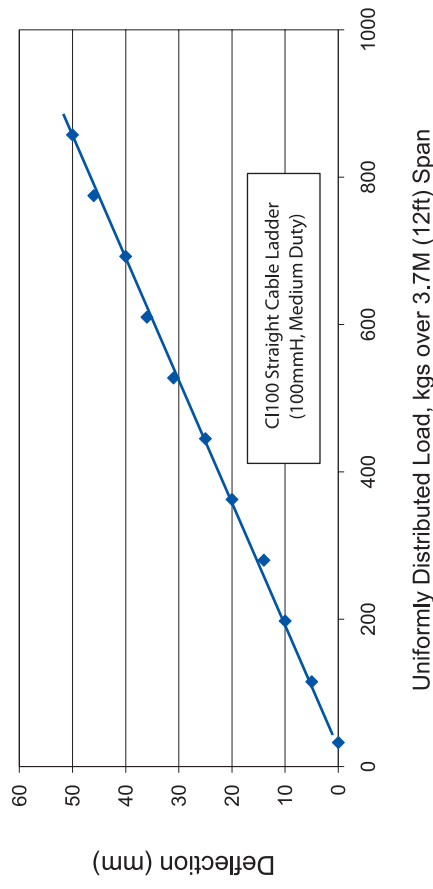

Note : The allowable working loads on other support spans are also available upon request.

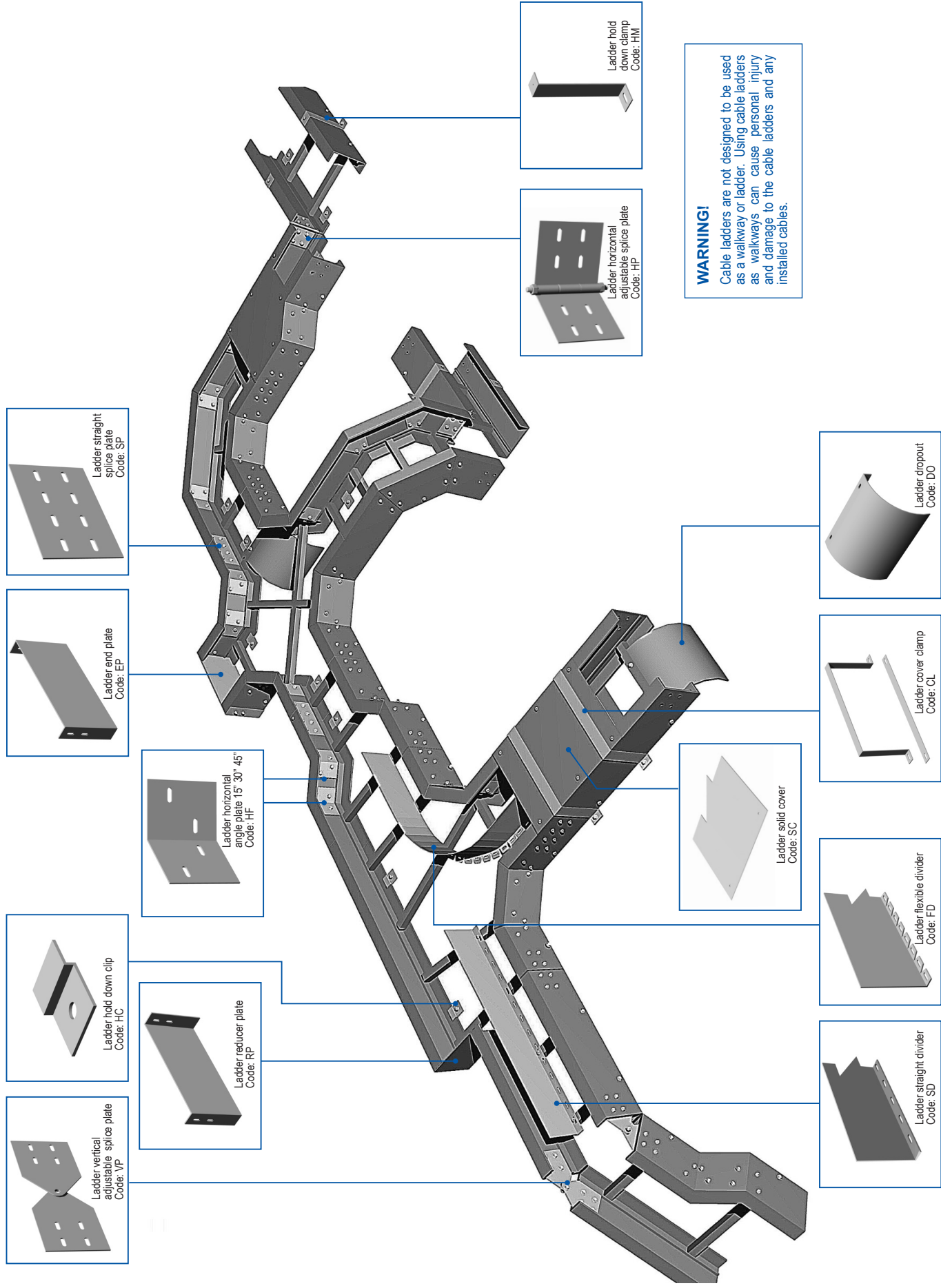

WARNING!
 Cable ladders are not designed to be used as a walkway or ladder. Using cable ladders as walkways can cause personal injury and damage to the cable ladders and any installed cables.

G Series Ladder, Extra Heavy Duty

- Length : 3000mm or 6000mm
- Ladder rung type : Box or Channel
- Rung Spacing : 230mm or 300mm (9" or 12")
- Joint plate : SS316 or GRP
- Fastener : M10x20L Carriage Bolt c/w Serrated Flange Nut (8 sets per joint plate) - SS316

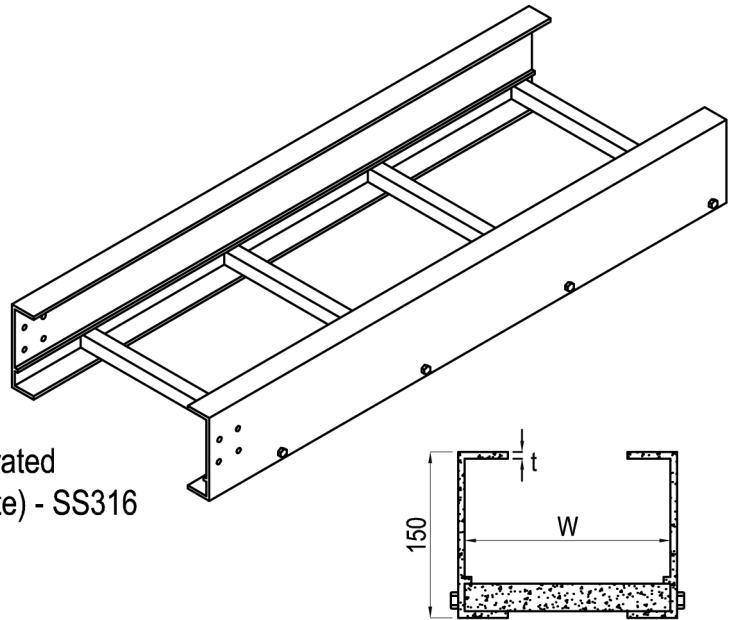

Series	H (mm)	NEMA Rating	W (mm)	Resin
GSL	150 mm	8A/B/C, 12A/B/C, 16A/B/C, 20A/B/C	150mm - 1000 mm	Polyester, Phenolic, Acrylic

Definition of Product Code (HOW TO ORDER)

e.g. GSL PE 150 60 30 3 B

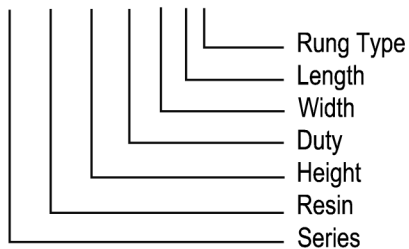

Product Code	Width	Weight
GSL PE 150 60 15 3 B	150 mm	3.06 kg/m
GSL PE 150 60 30 3 B	300 mm	3.40 kg/m
GSL PE 150 60 45 3 B	450 mm	3.73 kg/m
GSL PE 150 60 60 3 B	600 mm	4.07 kg/m
GSL PE 150 60 75 3 B	750 mm	4.40 kg/m
GSL PE 150 60 90 3 B	900 mm	4.73 kg/m

Rung Type

Box (B)

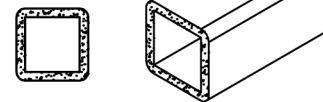

Strut (S)
(Plain)

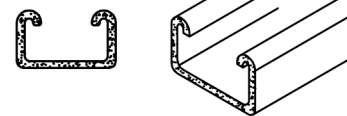

Strut (S)
(Slotted)

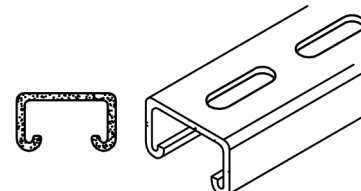

G Series Ladder, Heavy Duty

- Length : 3000mm or 6000mm
- Ladder rung type : Box or Channel
- Rung Spacing : 230mm or 300mm (9" or 12")
- Joint plate : SS316 or GRP
- Fastener : M10x20L Carriage Bolt c/w Serrated Flange Nut (8 sets per joint plate) - SS316

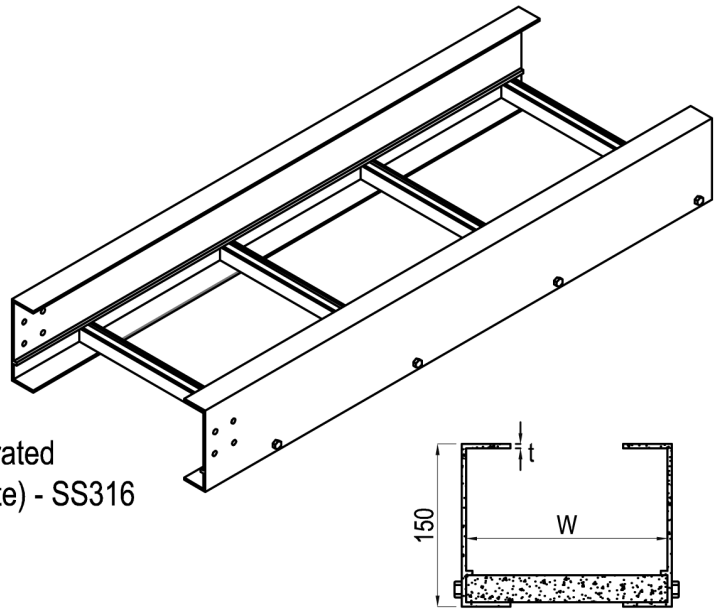

Model	H (mm)	NEMA Rating	W (mm)	Resin
GSL	150 mm	8A/B/C, 12A/B/C, 16A/B/C, 20A/B	150mm - 1000 mm	Polyester, Phenolic, Acrylic

Definition of Product Code (HOW TO ORDER)

e.g. GSL PE 150 40 30 3 B

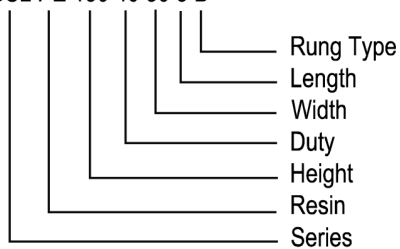

Product Code	Width	Weight
GSL PE 150 40 15 3 B	150 mm	2.22 kg/m
GSL PE 150 40 30 3 B	300 mm	2.55 kg/m
GSL PE 150 40 45 3 B	450 mm	2.88 kg/m
GSL PE 150 40 60 3 B	600 mm	3.22 kg/m
GSL PE 150 40 75 3 B	750 mm	3.55 kg/m
GSL PE 150 40 90 3 B	900 mm	3.88 kg/m

Rung Type

Box (B)

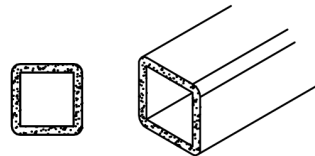

Strut (S)
(Plain)

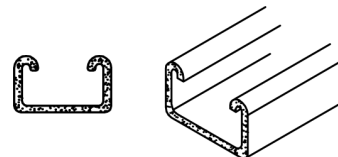

Strut (S)
(Slotted)

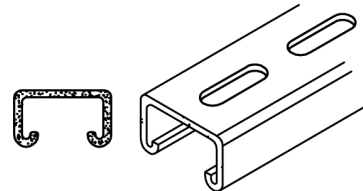

G Series Ladder, Medium Duty

- Length : 3000mm or 6000mm
- Ladder rung type : Box or Channel
- Rung Spacing : 230mm or 300mm (9" or 12")
- Joint plate : SS316 or **GRP**
- Fastener : M10x20L Carriage Bolt c/w Serrated Flange Nut (4 sets per joint plate) - SS316

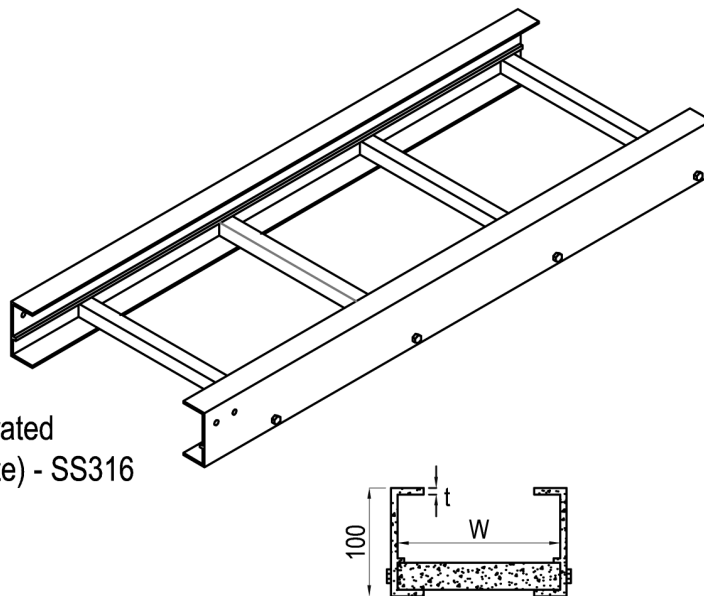

Model	H (mm)	NEMA Rating	W (mm)	Resin
GSL	100 mm	8A/B/C, 12A/B/C, 16A/B/C, 20A/B	150mm - 900 mm	Polyester, Phenolic, Acrylic

Definition of Product Code (HOW TO ORDER)

e.g. GSL PE 100 60 30 3 B

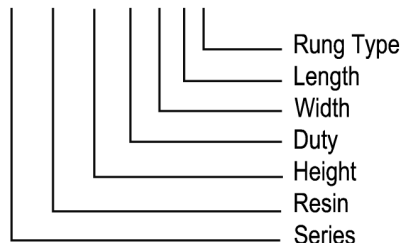

Product Code	Width	Weight
GSL PE 100 60 15 3 B	150 mm	2.11 kg/m
GSL PE 100 60 30 3 B	300 mm	2.45 kg/m
GSL PE 100 60 45 3 B	450 mm	2.78 kg/m
GSL PE 100 60 60 3 B	600 mm	3.11 kg/m
GSL PE 100 60 75 3 B	750 mm	3.44 kg/m
GSL PE 100 60 90 3 B	900 mm	3.77 kg/m

Rung Type

Box (B)

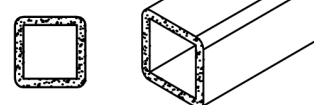

Strut (S)
(Plain)

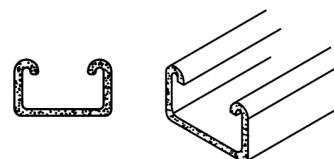

Strut (S)
(Slotted)

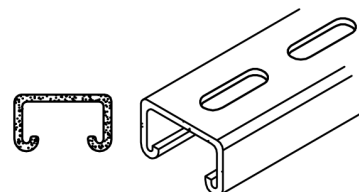

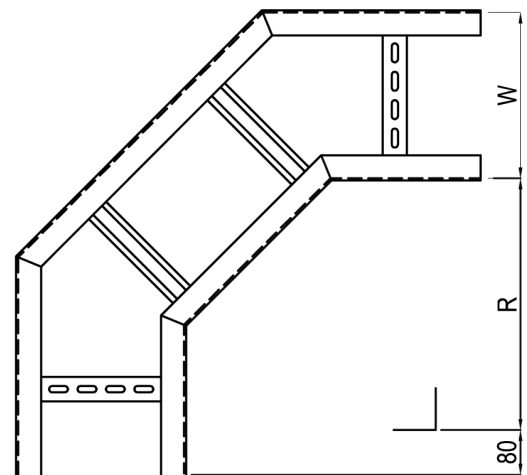
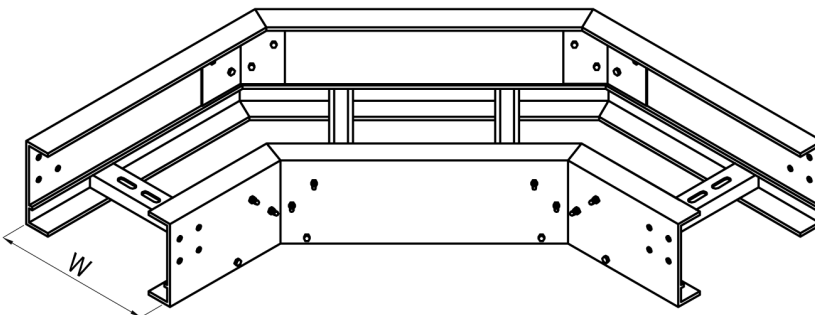
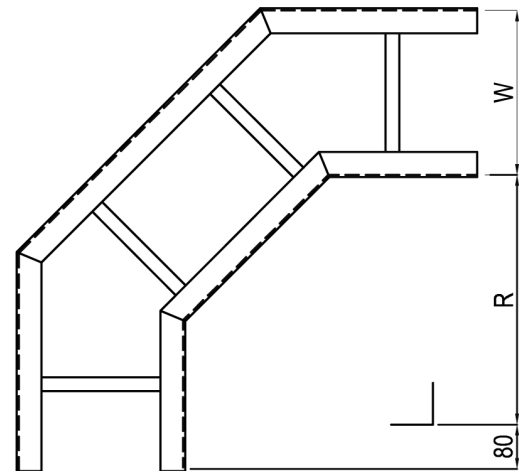
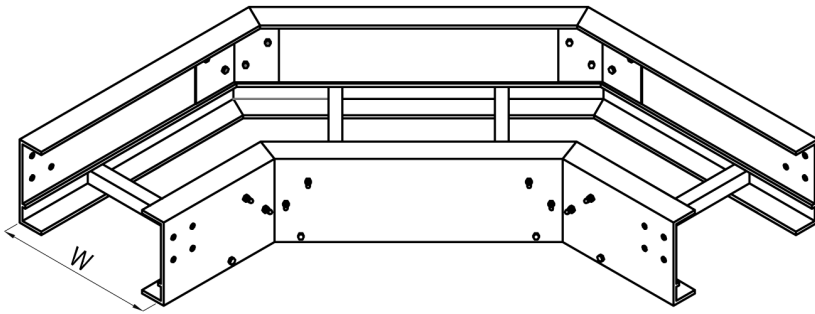

Segment Degree :

30°, 45°, 60°, 90°

Standard Radius (R), mm :

150, 300, 450, 600, 900

Standard Width (W), mm :

150, 300, 450, 600, 750, 900, 1000

Definition of Product Code (HOW TO ORDER)

e.g. GHE PE 150 60 30 90 R3 B

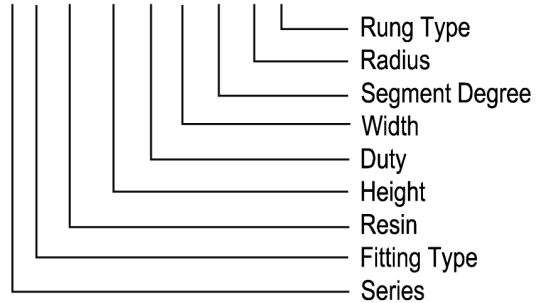

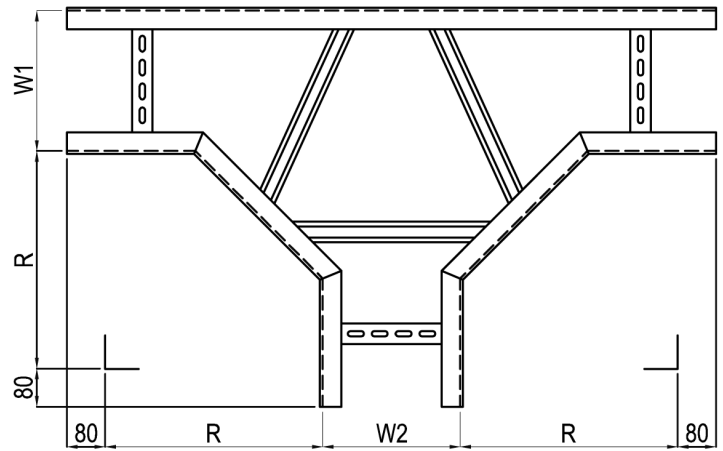
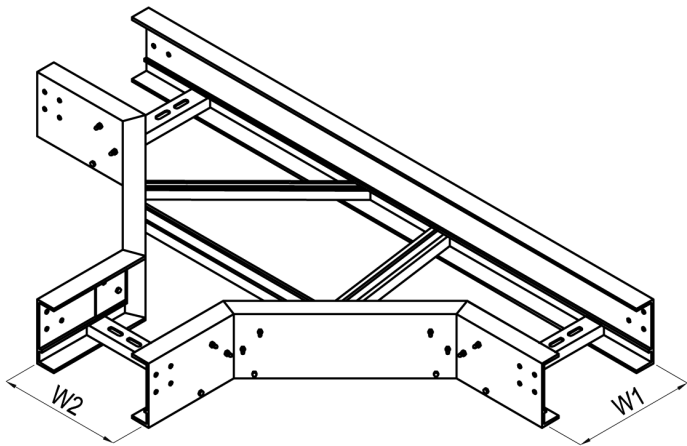
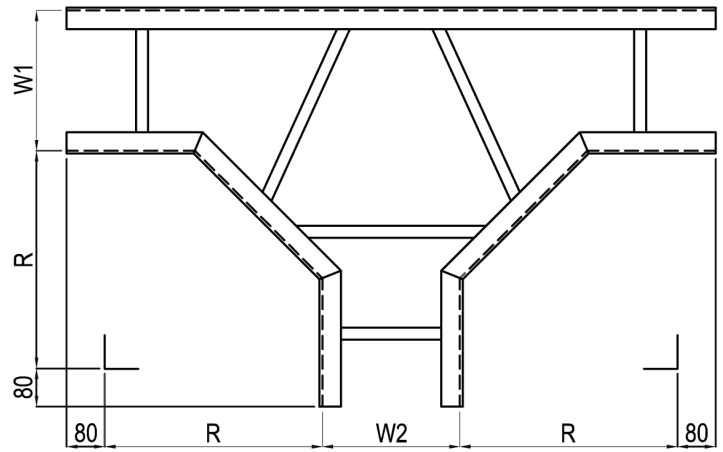
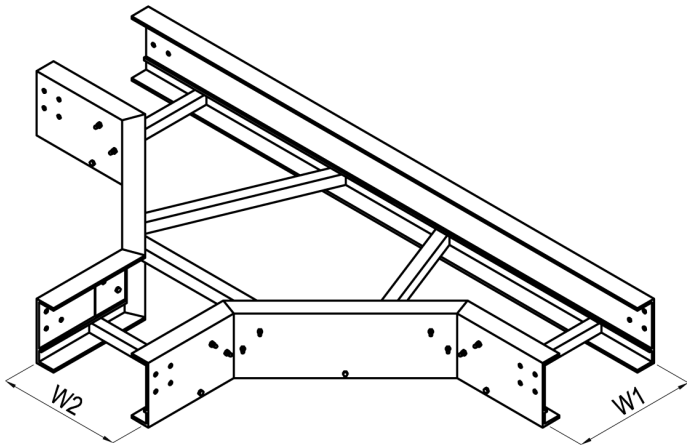

Standard Radius (R), mm :

150, 300, 450, 600, 900

Standard Width (W1/W2), mm :

150, 300, 450, 600, 750, 900, 1000

Equal/Unequal Tee :

W1 = W2 - Equal (Part No : TE)

W1 ≠ W2 - Unequal (Part No : TU)

Definition of Product Code (HOW TO ORDER)

e.g. GTE PE 150 60 30 30 R3 B

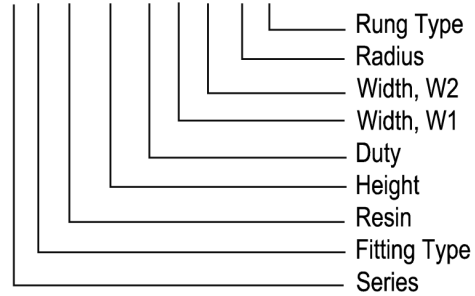

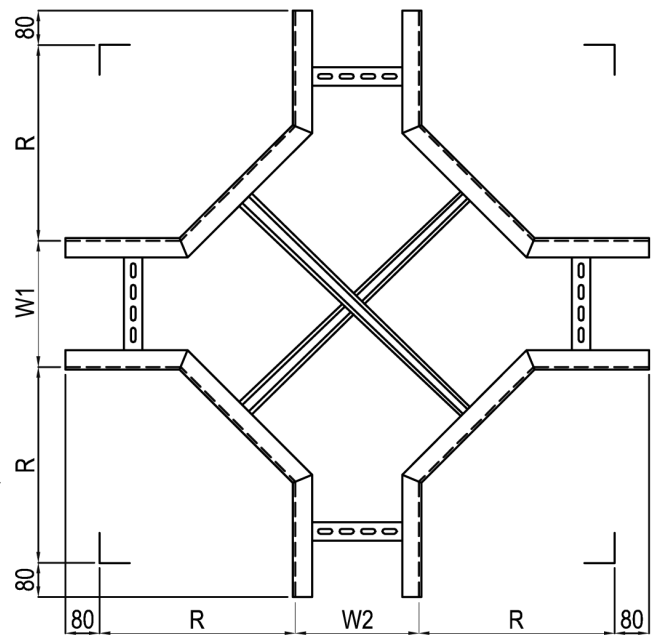
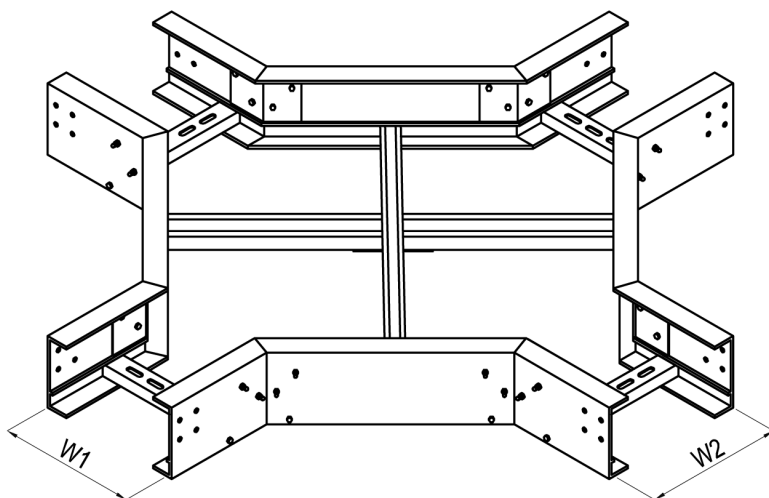
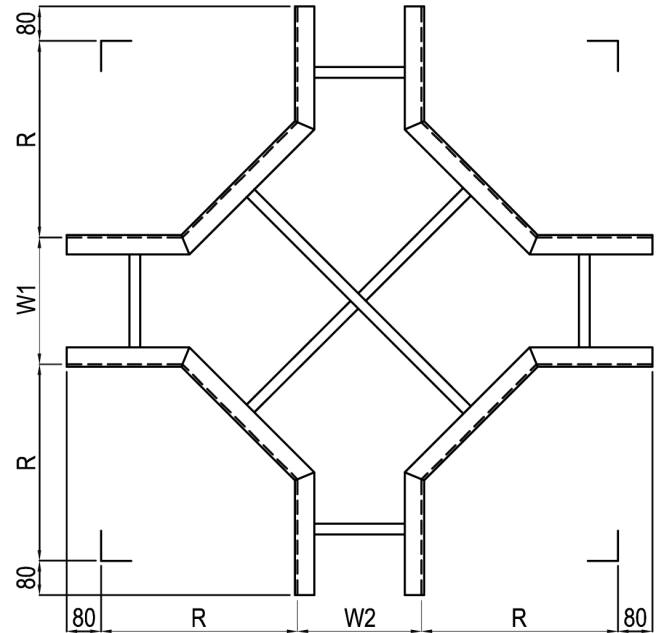
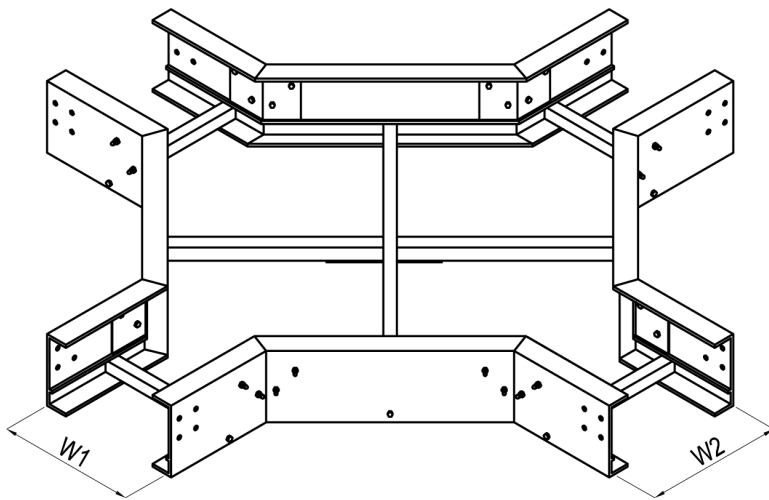

Standard Radius (R), mm :
150, 300, 450, 600, 900

Standard Width (W1/W2), mm :
150, 300, 450, 600, 750, 900, 1000

Equal/Unequal Crossover :
W1 = W2 - Equal (Part No : CE)
W1 ≠ W2 - Unequal (Part No : CU)

Definition of Product Code (HOW TO ORDER)

e.g. GCE PE 150 60 30 30 R3 B

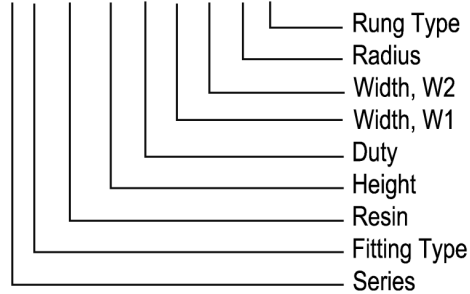

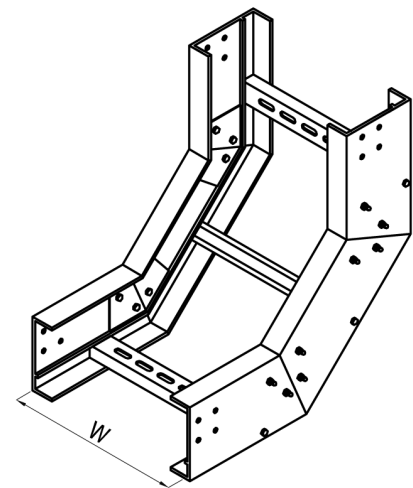
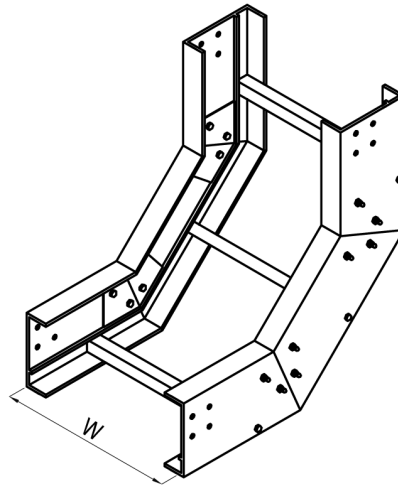
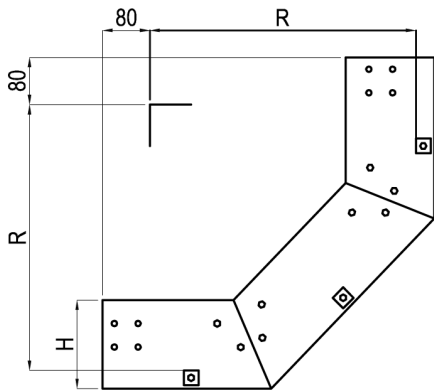

INSIDE RISER (Part No : AI)

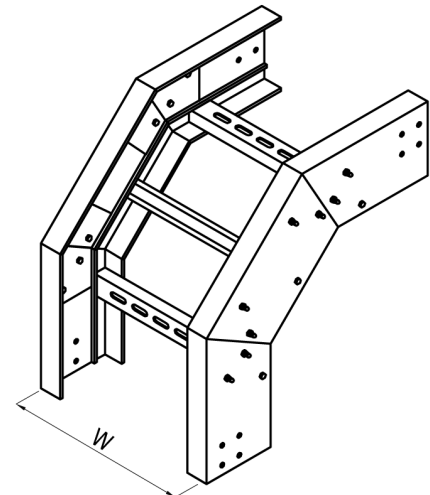
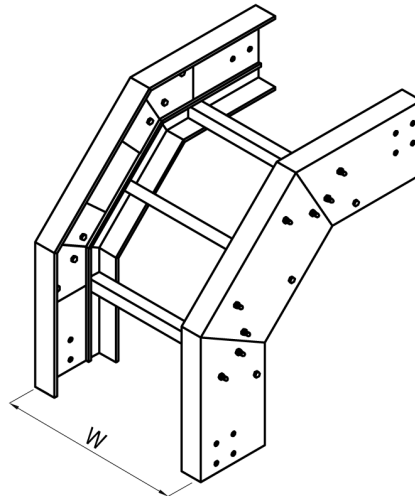
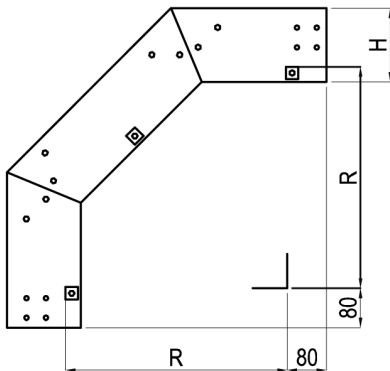

OUTSIDE RISER (Part No : AO)

Definition of Product Code (HOW TO ORDER)

e.g. GAO PE 150 60 30 90 R3 B

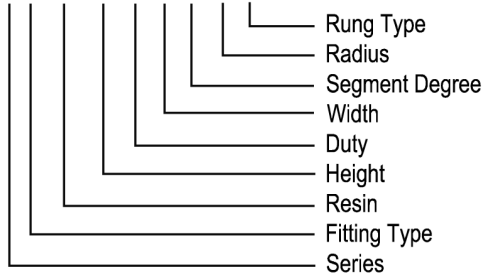

Definition of Product Code (HOW TO ORDER)

e.g. GFR PE 150 60 30 B

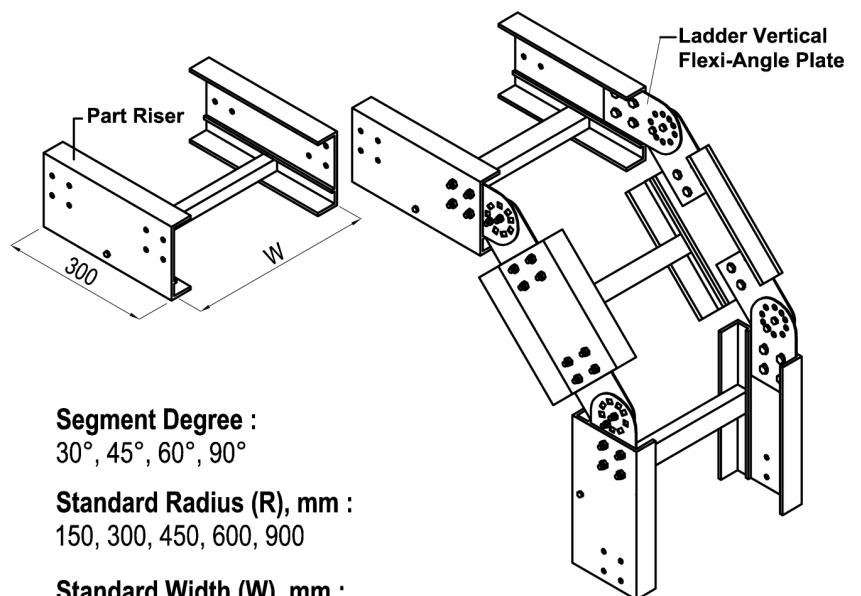
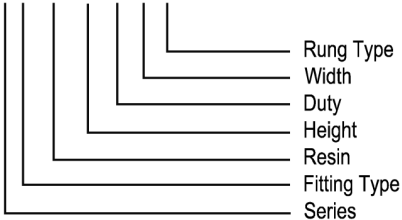

Segment Degree :
30°, 45°, 60°, 90°

Standard Radius (R), mm :
150, 300, 450, 600, 900

Standard Width (W), mm :
150, 300, 450, 600, 750, 900, 1000

FLEXIBLE RISER (Part No : FR)

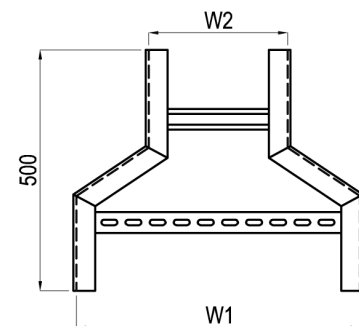
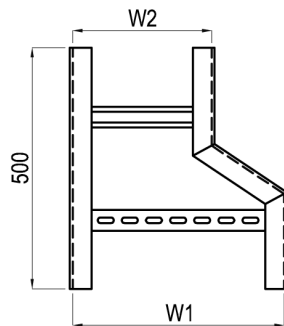
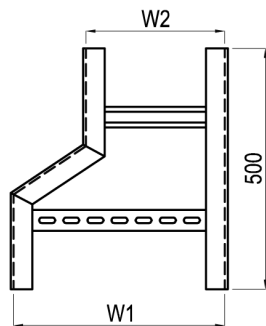
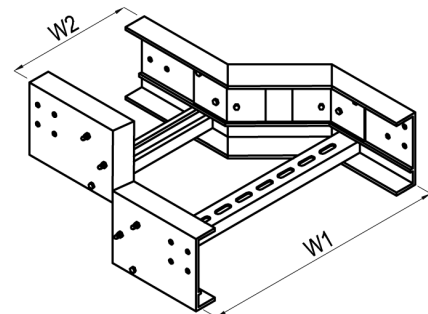
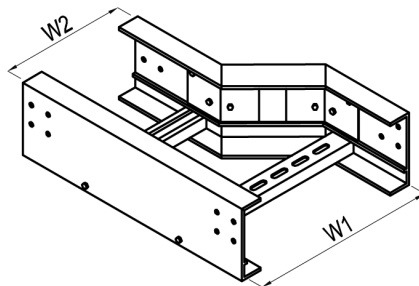
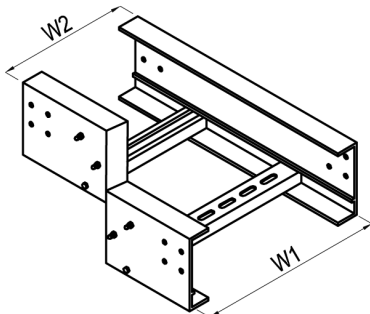
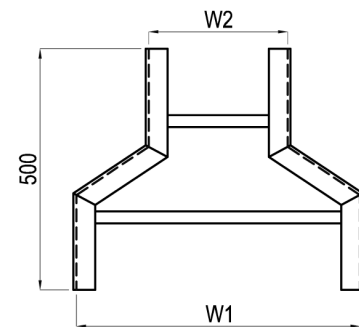
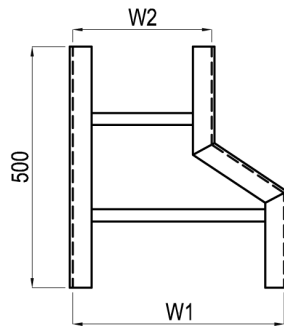
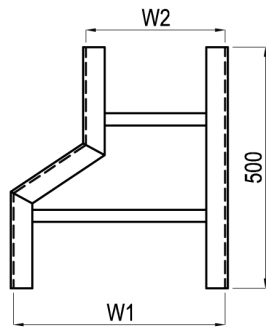
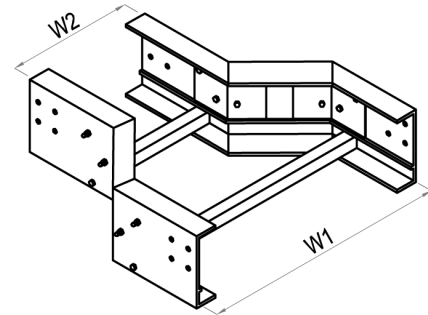
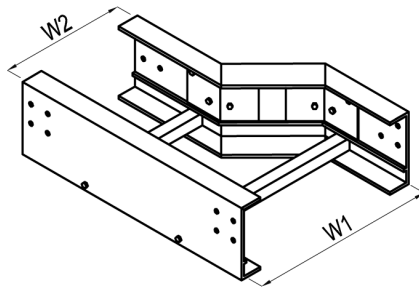
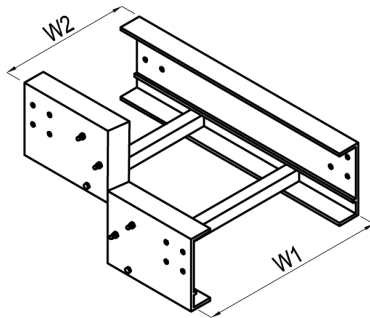

LEFT HAND REDUCER
(Part No : DL)

RIGHT HAND REDUCER
(Part No : DR)

CONCENTRIC REDUCER
(Part No : DC)

Standard Width (W1/W2), mm :
150, 300, 450, 600, 750, 900, 1000

Definition of Product Code (HOW TO ORDER)

e.g. GDR PE 150 60 30 15 B

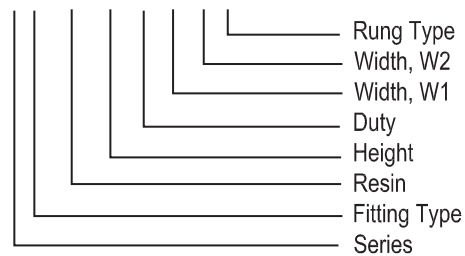

1
Ladder Straight Splice Plate
 Code: SP

Fastener: 4 / 8 sets of M10x20 Carriage Bolt & Serrated Flange Nut

2
Ladder Horizontal Adjustable Splice Plate
 Code: HP

Fastener: 8 sets of M10x20 Carriage Bolt & Serrated Flange Nut

3
Ladder Vertical Adjustable Splice Plate
 Code: VP

Fastener: 8 sets of M10x20 Carriage Bolt & Serrated Flange Nut

10
Ladder Dropout
 Code: DO

Fastener: 2 sets of M6x40 Pan Head Screw & Serrated Flange Nut

11
Ladder End Plate
 Code: EP

Fastener: 4 sets of M10x20 Carriage Bolt & Serrated Flange Nut

12
Ladder Reducer Plate
 Code: RP

Fastener: 4 sets of M10x20 Carriage Bolt & Serrated Flange Nut

4
Ladder Vertical Flexi-Angle Plate
 Code: VF

Fastener: 8 sets of M10x20 Carriage Bolt & Serrated Flange Nut

5
Ladder Horizontal Angle Plate -15°, 30°, 45°
 Code: HF

Fastener: 4 sets of M10x20 Carriage Bolt & Serrated Flange Nut

6
Ladder Straight Divider
 Code: SD

Fastener: 2 sets of M6x40 Pan Head Screw & Serrated Flange Nut / Spring Nut & Flat Washer

13
Ladder Cover Clamp
 Code: CL

Fastener: 2 sets of M6x20 Hex Bolt & Serrated Flange Nut

14
Ladder Solid Cover
 Code: SC

Fastener: 6 sets of M4 Self Tapping Screw

15
Sealing Compound For GRP

7
Ladder Flexible Divider
 Code: FD

Fastener: 2 sets of M6x40 Pan Head Screw & Serrated Flange Nut

8
Ladder Hold Down Clamp
 Code: HM

Fastener: 1 set of M10x30 Hex Bolt & Serrated Flange Nut & M4 Self Tapping Screw

9
Ladder Hold Down Clip
 Code: HC

Fastener: 1 set of M10x30 Hex Bolt & Serrated Flange Nut

16
Stand Off Cover Bracket
 Code: SB

17
SS316 Ring Insert
 Code: IR

Definition of Product Code (HOW TO ORDER)
 For item 1,2,3,4,5,8,9
 e.g. GSP S6 150 15

- Thickness
- Height
- Material
- Code
- Series

Definition of Product Code (HOW TO ORDER)
 For item 6,7
 e.g. GSD S6 150 15 3

- Length
- Thickness
- Height
- Material
- Code
- Series

Definition of Product Code (HOW TO ORDER)
 For item 10
 e.g. GDO S6 150 15 30 R3

- Radius
- Width
- Thickness
- Height
- Material
- Code
- Series

Definition of Product Code (HOW TO ORDER)
 For item 11,12,13
 e.g. GEP S6 150 15 30

- Width
- Thickness
- Height
- Material
- Code
- Series

Definition of Product Code (HOW TO ORDER)
 For item 14
 e.g. GSC PE 150 20 30 3

- Length
- Width
- Thickness
- Height
- Resin
- Code
- Series

Definition of Product Code (HOW TO ORDER)
 For item 16
 e.g. GSB S6 15

- Thickness
- Material
- Code
- Series

Definition of Product Code (HOW TO ORDER)
 For item 17
 e.g. GIR S6 15

- Thickness
- Material
- Code
- Series

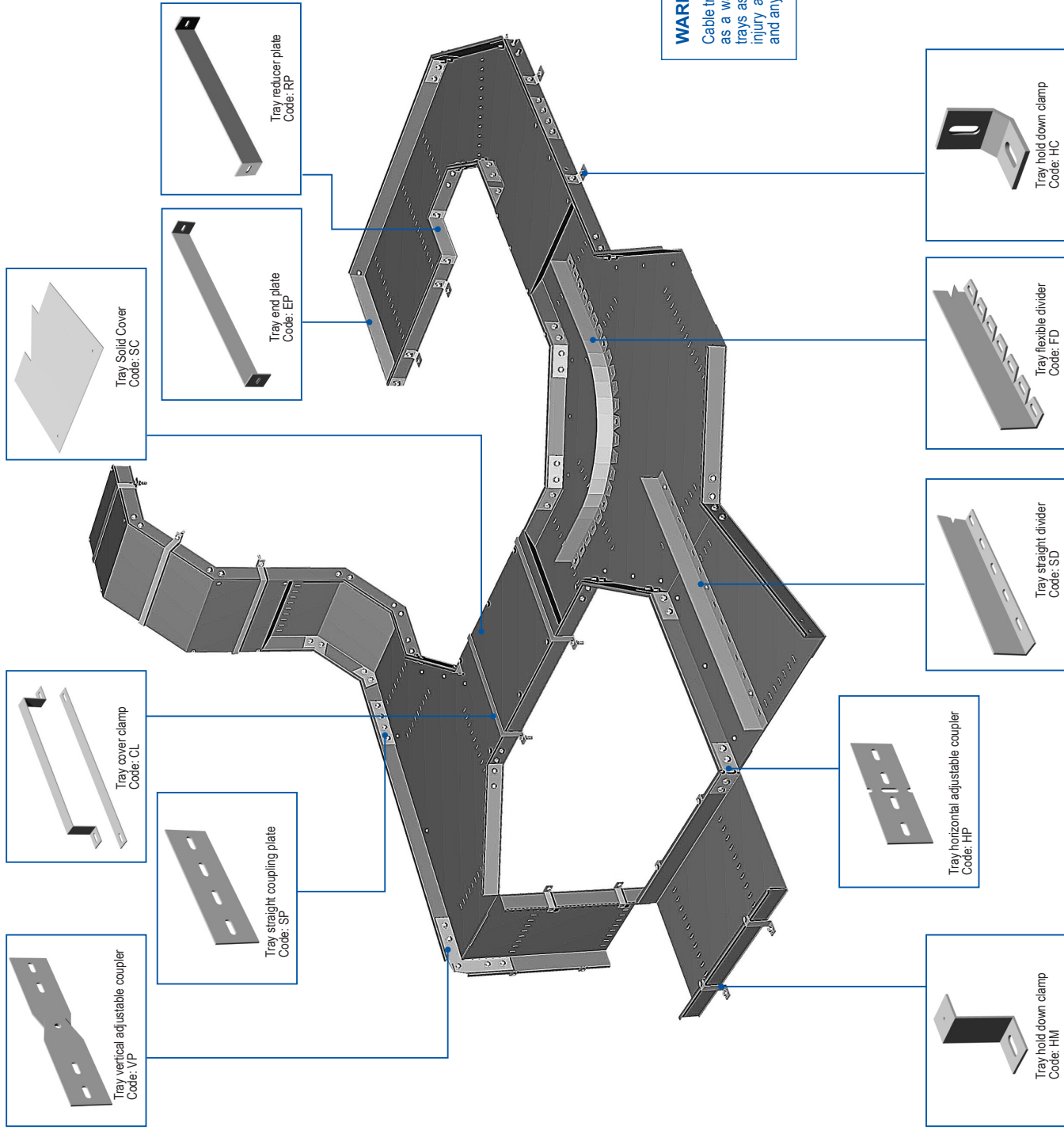

WARNING!
 Cable trays are not designed to be used as a walkway or ladder. Using cable trays as walkways can cause personal injury and damage to the cable trays and any installed cables.

Tray vertical adjustable coupler
Code: VP

Tray straight coupling plate
Code: SP

Tray cover clamp
Code: CL

Tray Solid Cover
Code: SC

Tray end plate
Code: EP

Tray reducer plate
Code: RP

Tray horizontal adjustable coupler
Code: HP

Tray hold down clamp
Code: HM

Tray straight divider
Code: SD

Tray flexible divider
Code: FD

Tray hold down clamp
Code: HC

Cable Tray

Length : 3000mm or 6000mm

Dimension : 7mm x 20mm

Coupler : SS316 GRP

Fastener : M6x16L Carriage Bolt c/w Serrated Flange Nut
(4 sets per coupler) - SS316

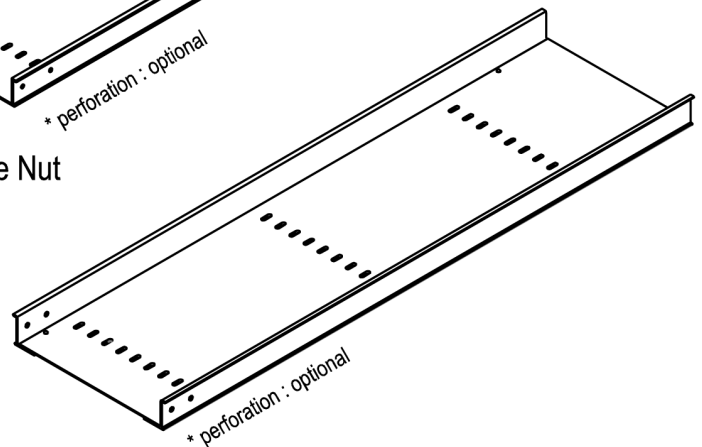
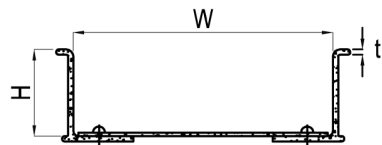
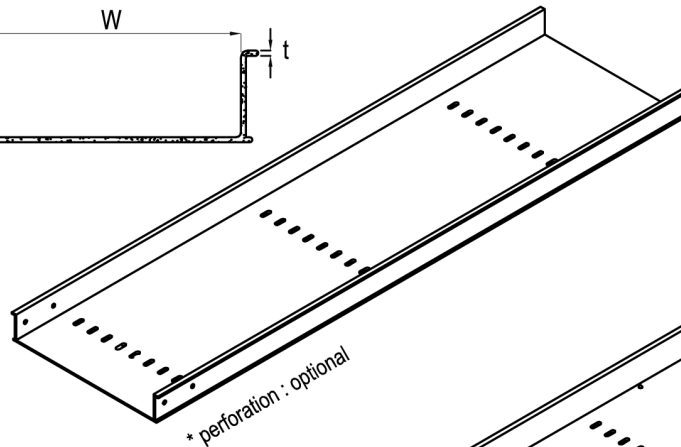
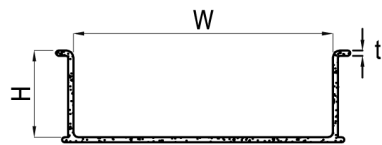

Series	H (mm)	Width (W)	Resin
PST	50 mm	50 mm, 100 mm, 150 mm, 300 mm, 450 mm	Polyester, Phenolic, Acrylic
	80 mm	100 mm, 150 mm, 200mm	

Definition of Product Code (HOW TO ORDER)

e.g. PST PE 50 30 15 3

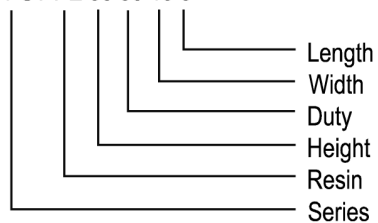

Product Code	Width	Weight
PST PE 50 30 5 3	50 mm	0.98 kg/m
PST PE 50 30 10 3	100 mm	1.25 kg/m
PST PE 50 30 15 3	150 mm	1.50 kg/m
PST PE 50 30 30 3	300 mm	2.24 kg/m

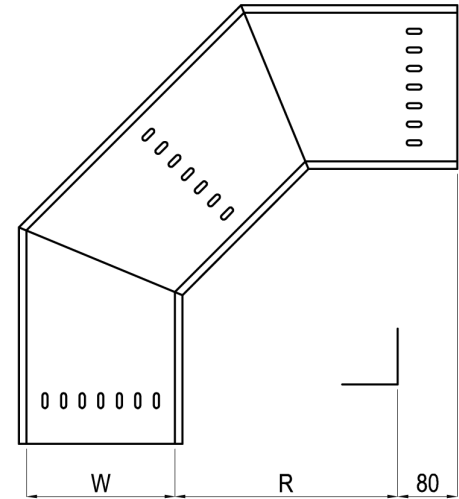
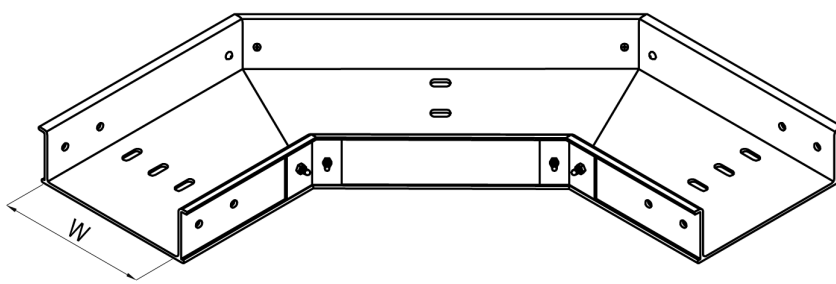

Segment Degree :

30°, 45°, 60°, 90°

Standard Radius (R), mm :

100, 200, 300

Standard Width (W), mm :

50, 100, 150, 300, 450

Definition of Product Code (HOW TO ORDER)

e.g. PHE PE 50 30 15 90 R2

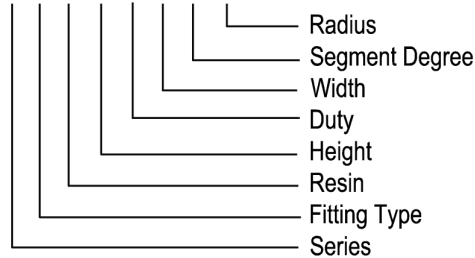

GRP Cable Tray (Equal/Unequal Tee)

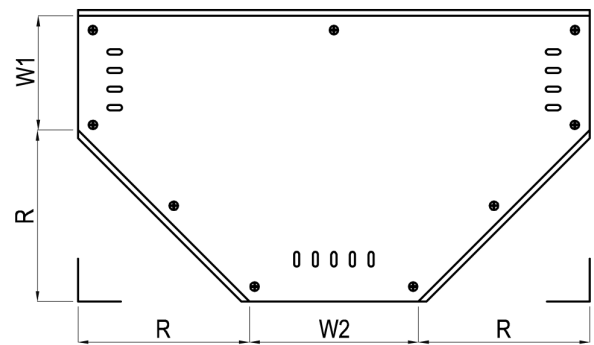
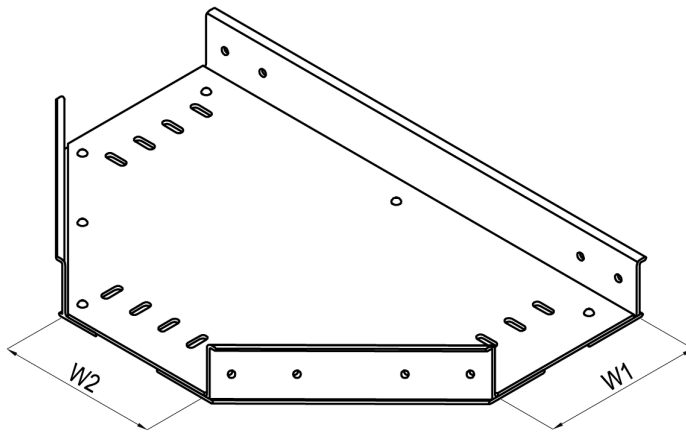

Standard Radius (R), mm :

100, 200, 300

Standard Width (W), mm :

50, 100, 150, 300, 450

Equal/Unequal Tee :

W1 = W2 - Equal (Part No : TE)

W1 ≠ W2 - Unequal (Part No : TU)

Definition of Product Code (HOW TO ORDER)

e.g. PTE PE 50 30 15 15 R2

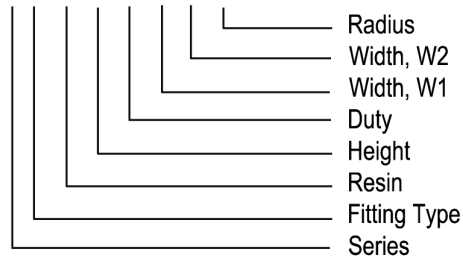

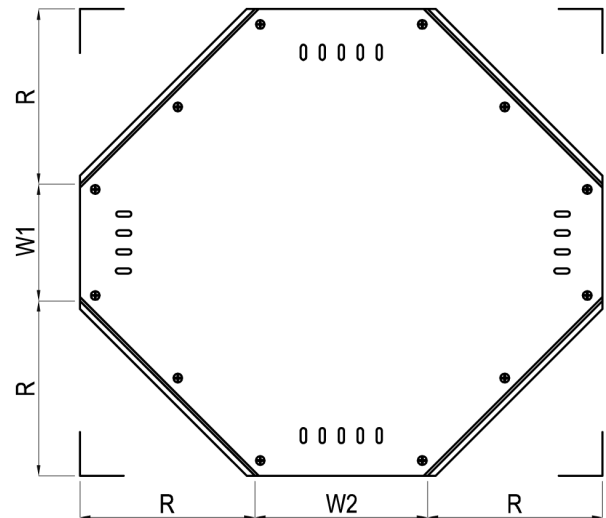
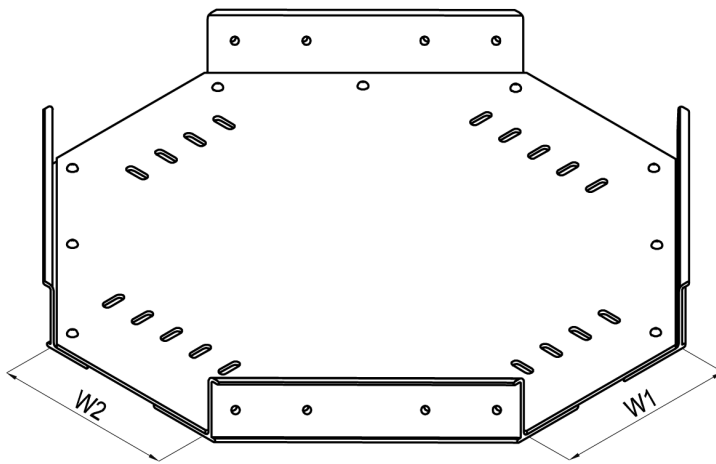

Standard Radius (R), mm :

100, 200, 300

Standard Width (W), mm :

50, 100, 150, 300, 450

Equal/Unequal Crossover :

W1 = W2 - Equal (Part No : CE)

W1 ≠ W2 - Unequal (Part No : CU)

Definition of Product Code (HOW TO ORDER)

e.g. PCE PE 50 30 15 15 R2

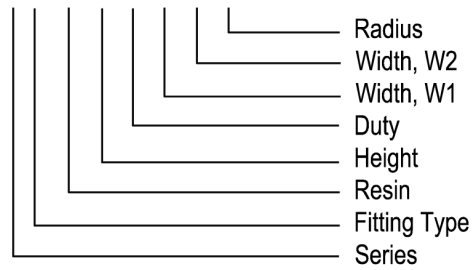

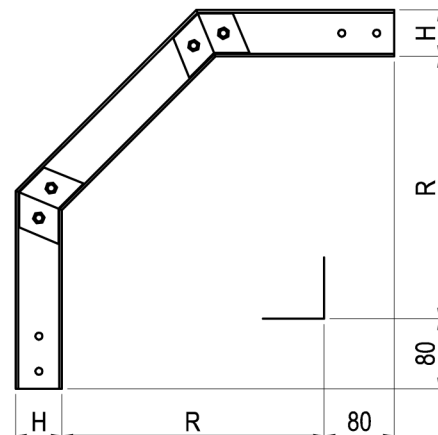
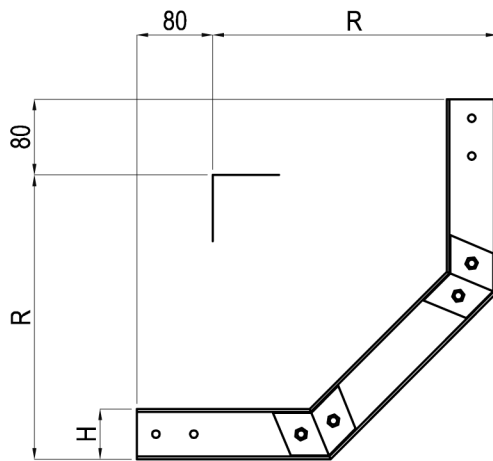
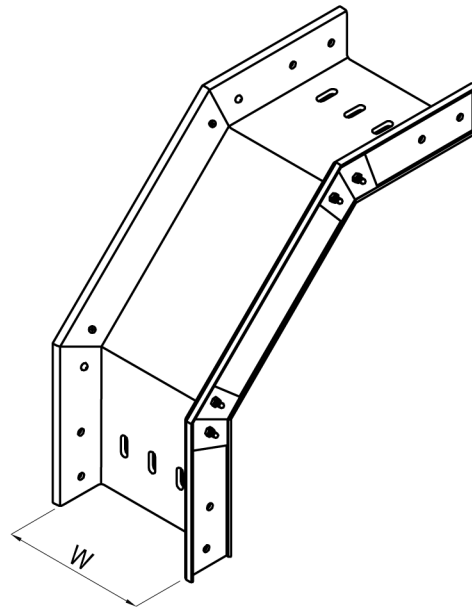
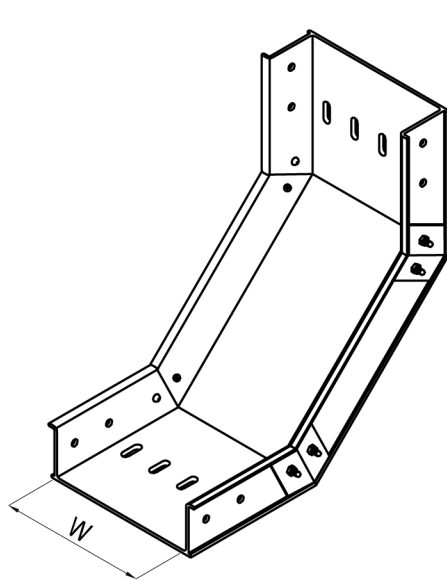

INSIDE RISER (Part No : AI)

OUTSIDE RISER (Part No : AO)

Segment Degree :
30°, 45°, 60°, 90°

Standard Radius (R), mm :
100, 200, 300

Standard Width (W), mm :
50, 100, 150, 300, 450

Definition of Product Code (HOW TO ORDER)

e.g. PAO PE 50 30 15 90 R2

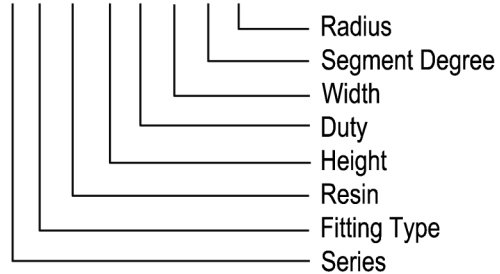

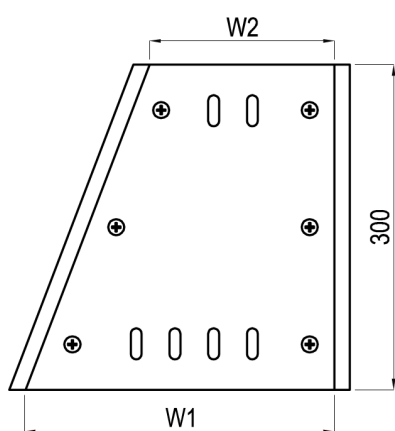
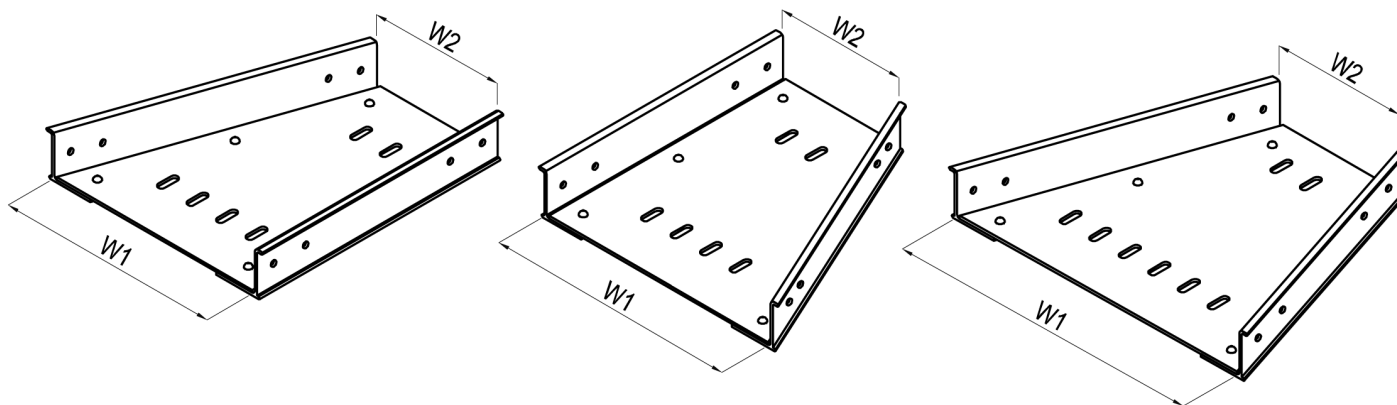

LEFT HAND REDUCER
(Part No : DL)

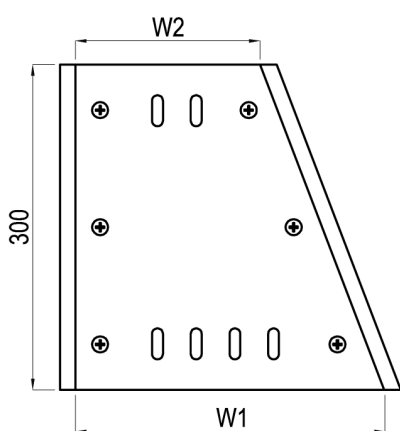

RIGHT HAND REDUCER
(Part No : DR)

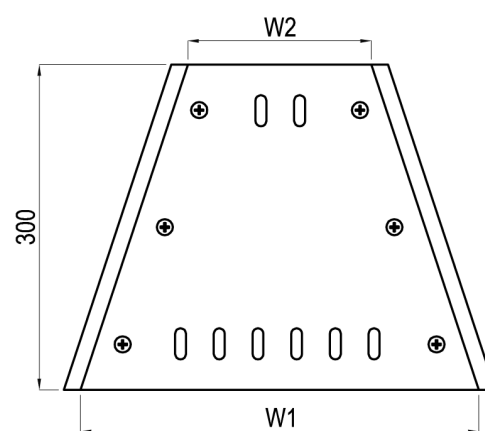

CONCENTRIC REDUCER
(Part No : DC)

Standard Width (W), mm :
50, 100, 150, 300, 450

Definition of Product Code (HOW TO ORDER)

e.g. PDR PE 50 30 30 15

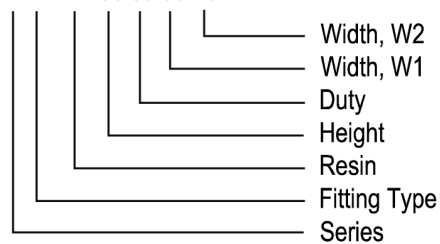

Tray Straight Coupling Plate **1**
Code: SP

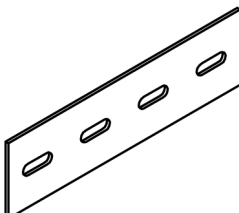

Fastener: 4 sets of M6x16 Carriage Bolt & Serrated Flange Nut

Tray Horizontal Adjustable Coupler **2**
Code: HP

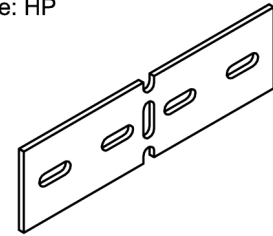

Fastener: 4 sets of M6x16 Carriage Bolt & Serrated Flange Nut

Tray Vertical Adjustable Coupler **3**
Code: VP

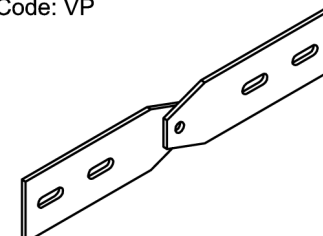

Fastener: 4 sets of M6x16 Carriage Bolt & Serrated Flange Nut

Tray Straight Divider **4**
Code: SD

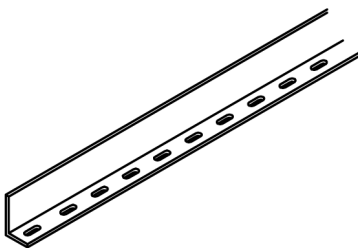

Fastener: 2 sets of M6x16 Pan Head Screw & Serrated Flange Nut

Tray Flexible Divider **5**
Code: FD

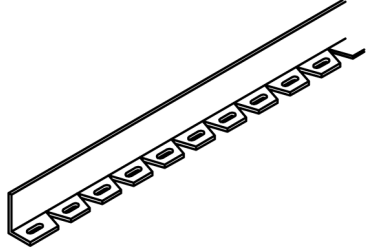

Fastener: 2 sets of M6x16 Pan Head Screw & Serrated Flange Nut

Tray Solid Cover **6**
Code: SC

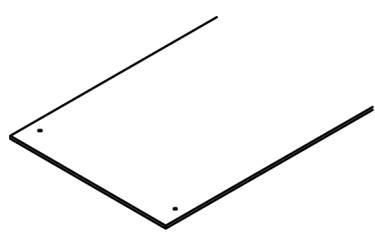

Fastener: 6 sets of M4 Self Tapping Screw

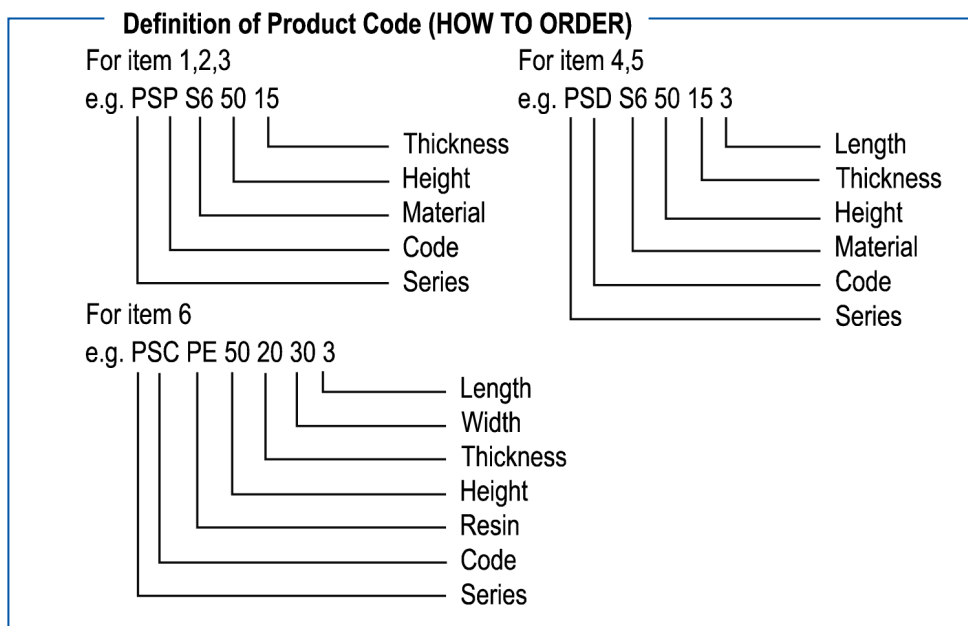

Tray Cover Clamp

Code: CL

7

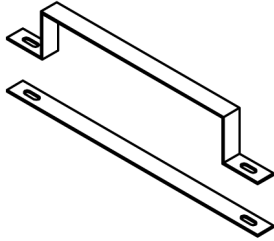

Fastener: 2 sets of M6x20 Hex Bolt & Serrated Flange Nut

Tray Hold Down Clamp

Code: HM

8

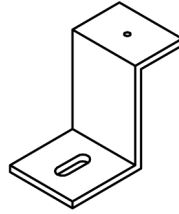

Fastener: 1 set of M6x30 Hex Bolt & Serrated Flange Nut / Spring Nut & Flat Washer & M4 Self Tapping Screw

Tray Hold Down Clip

Code: HC

9

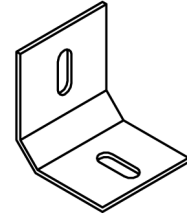

Fastener: 1 set of M6x16 Carriage Bolt & Serrated Flange Nut & 1 set of M6x30 Hex Bolt & Serrated Flange Nut / Spring Nut & Flat Washer

Tray Reducer Plate

Code: RP

10

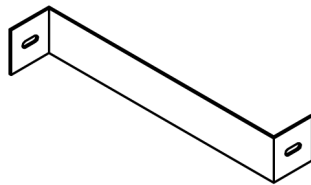

Fastener: 2 sets of M6x16 Carriage Bolt & Serrated Flange Nut

Tray Horizontal Angle Plate

- 15°, 30°, 45°
Code: HF

11

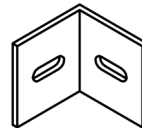

Fastener: 2 sets of M6x16 Carriage Bolt & Serrated Flange Nut

Tray End Plate

Code: EP

12

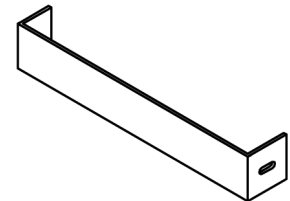

Fastener: 2 sets of M6x16 Carriage Bolt & Serrated Flange Nut

Definition of Product Code (HOW TO ORDER)

For item 8, 9, 11

e.g. PHM S6 50 15

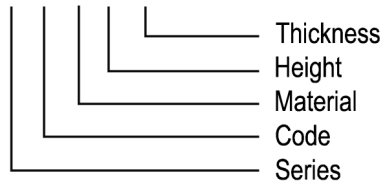

For item 7, 10, 12

e.g. PCL S6 50 15 15

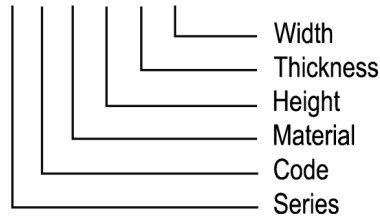

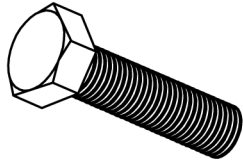

M10x30L HEX BOLT

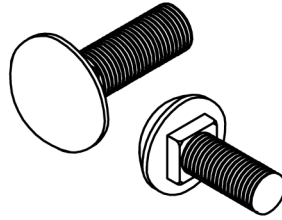

M10x20L CARRIAGE BOLT

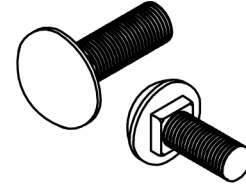

M6x16L CARRIAGE BOLT



M4 SELF TAPPING SCREW

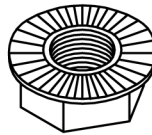

HEX SERRATED FLANGE NUT

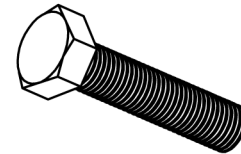

M8x30L HEX BOLT

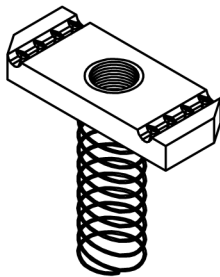

LONG SPRING NUT

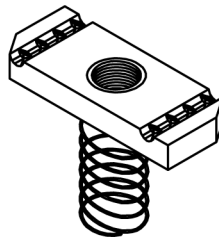

SHORT SPRING NUT

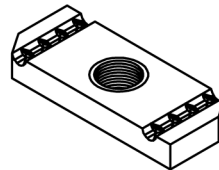

CHANNEL NUT WITHOUT SPRING

Material : Zinc-plated, Galvanised and Stainless Steel available on request.





TRI-STAR INDUSTRIES PTE LTD
SINGAPORE FACTORY
 36 Joo Koon Road, Singapore 628988
 Tel (65) 6266 3636
 Fax (65) 6265 3635 / 6265 2801
 Email sales@tristar.com.sg
 Web www.tristar.com.sg

TRI STAR MIDDLE EAST
INDUSTRIES LLC
DUBAI FACTORY
 Warehouse No.89, DIP Phase 2
 Jebel Ali, Dubai, UAE
 Tel (971) (4) 8847 707
 Fax (971) (4) 8847 709
 Email sales@tristar-mideast.com

TRI-STAR INDUSTRIES
(SHANGHAI) CO., LTD
SHANGHAI FACTORY
 Tel (86 21) 5727 7070
 Fax (86 21) 5727 1165
 Email sales@tristar-cn.com

TRISTAR INDUSTRIES
KOREA LTD
SOUTH KOREA FACTORY
 Tel (82) 070 8031 0699
 Email sales@tristar-kr.com

SBN INDUSTRIES SDN BHD
 Malaysia

JOHOR FACTORY
 6 Jalan Penaga
 Perindustrian Kota Putri
 81750 Masai, Johor
 West Malaysia
 Tel (607) 388 2521
 Fax (607) 388 2523
 Email sales@sbnbiz.com
 Web www.sbnbiz.com

KL OFFICE
 Tel (603) 2288 1831 / 1832
 Fax (603) 2288 1833
 Email sbnkl@sbnbiz.com

SARAWAK OFFICE
 Tel (608) 565 1600
 Fax (608) 565 7180
 Email sbnmiri@sbnbiz.com

TRENGGANU OFFICE
 Tel (609) 859 7600
 Fax (609) 859 7701
 Email sbnkm@sbnbiz.com

LINUS PRODUCTS INC
HOUSTON DISTRIBUTION CENTRE
 5516 Clara Road
 Houston, TX 77041
 USA
 Tel (1 713) 466 6466
 Fax (1 713) 466 1814
 Email sales@linusproducts.com

PT SOUTHERN TRISTAR
JAKARTA FACTORY
 JL Jababeka II, TOB Block C
 No.17J Cikarang Industrial Estate
 Cikarang, Bekasi 17550
 Indonesia
 Tel (62 21) 893 5162
 Fax (62 21) 893 5163
 Email sales@ptsts.com

BATAM FACTORY
 JL Engkau Putri Komp
 Executive Industrial Park
 Block D2, No.11 Batam Centre
 Batam 29434, Indonesia
 Tel (62 778) 748 2263
 Fax (62 778) 748 2262
 Email batamsales@ptsts.com

TRISTAR AUSTRALIA PTY LTD
PERTH FACTORY
 Unit 5/30 Howson Way
 Bibra Lake, Western Australia 6163
 Tel (61) 8 9494 2151
 Fax (61) 8 9434 9206
 Email sales@tristar-au.com